



TOK-TOK



TOK-TOK

Empowering collaboration and flexibility, The TOK-TOK range has been thoughtfully expressed to create environments where innovation takes the forefront. With a sophisticated cable management reticulating power beneath the work surface, TOK-TOK declutters the worktop to ensure your workspace empowers you to the fullest.

Different types of tasks call for different types of support. TOK-TOK's versatile design allows it to compliment a range of different configurations and applications, providing you with empowering versatility.



Created with integrated tabletop power and a sophisticated cable management system, TOK-TOK Conference tables are designed to keep devices powered up and cords hidden away.



01 Versatile performance

TOK-TOK's flexible framing system provides the flexibility and versatility required in modern flexible working environments.

02 An aesthetic to match your style

TOK-TOK provides a complete family of table product options, allowing you to choose an aesthetic and style that best matches you.

03 Powering collaboration

Easy to use and access, TOK-TOK's cable management system hides cords in a clean and functional way, empowering you to collaborate more effectively.

04 A Market innovator

TOK-TOK's flexibility makes it the perfect product for training rooms, meeting rooms or as temporary desking; a truly innovative approach to versatile design.

05 TOK-TOK's Legs

Durable and tactile, TOK-TOK's uniquely versatile leg design expresses flexibility through its design. Available in a range of finishes.

06 Adjustable Glides

TOK-TOK's adjustable glides make minor adjustments hassle free, meaning you can focus without any nuisances.

07 Perfect for collaboration

Inspired by the diverse activities and flexibility required in agile environments, TOK-TOK empowers collaboration through innovative design; Empowering you to do more.

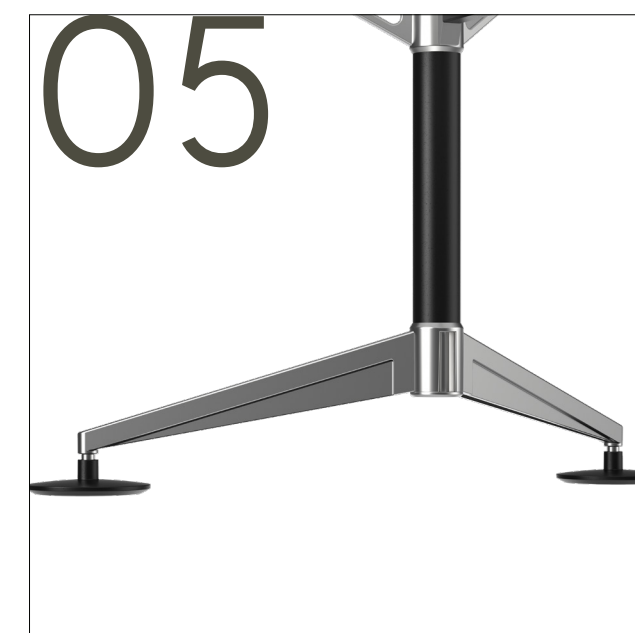

TOK-TOK has been thoughtfully designed to create a complete family of versatile and flexible arrangements for your office, ensuring design continuity throughout the workspace.



TOK-TOK

TECHNICAL SPECIFICATIONS

TOK-TOK

TABLES

TOK-TOK 2200 x 1200

Materials Information

1. Tops

25mm commercial Melamine, Laminate or Veneer worktops. Solid wood or ABS edging.

2. Supports (Cantilever brackets and Outriggers)

TOK-TOK's Legs are all manufactured using Polished Aluminium. White or Black powder-coat comes as standard. Other Colours can be made available as specified.

3. Frame

TOK-TOK's frames are all manufactured using Powder-coated Steel. White or Black powder-coat comes as standard. Other Colours can be made available as specified.

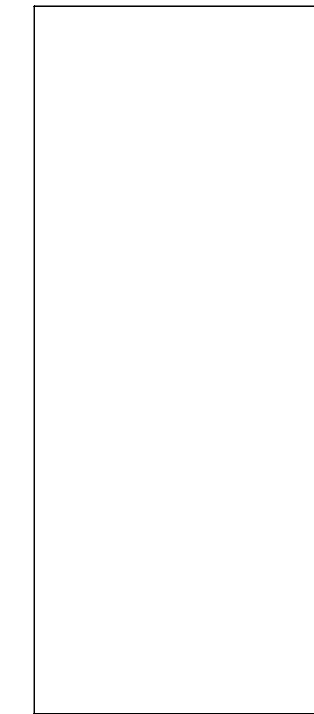

TOP VIEW

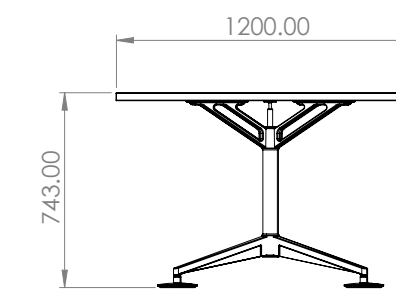

FRONT VIEW

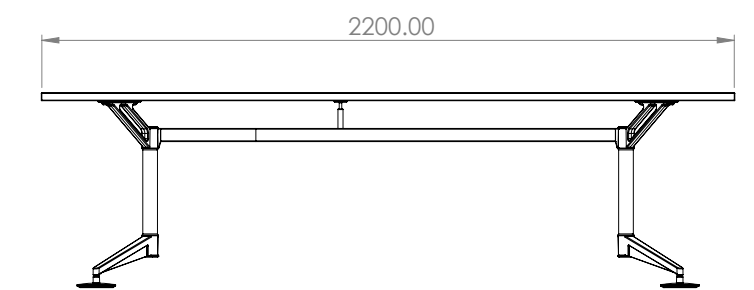

RIGHT-SIDE VIEW

TOK-TOK 4200 x 1300

Materials Information

1. Tops

25mm commercial Melamine, Laminate or Veneer worktops. Solid wood or ABS edging.

2. Supports (Cantilever brackets and Outriggers)

TOK-TOK's Legs are all manufactured using Polished Aluminium. White or Black powder-coat comes as standard. Other Colours can be made available as specified.

3. Frame

TOK-TOK's frames are all manufactured using powder-coated Steel. White or Black powder-coat comes as standard. Other Colours can be made available as specified.

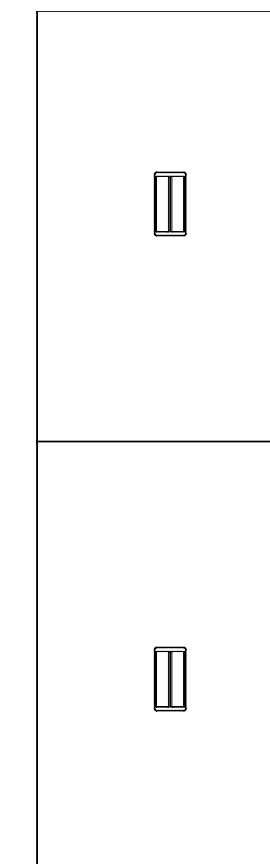

TOP VIEW

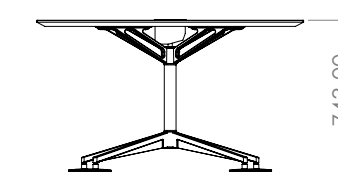

FRONT VIEW

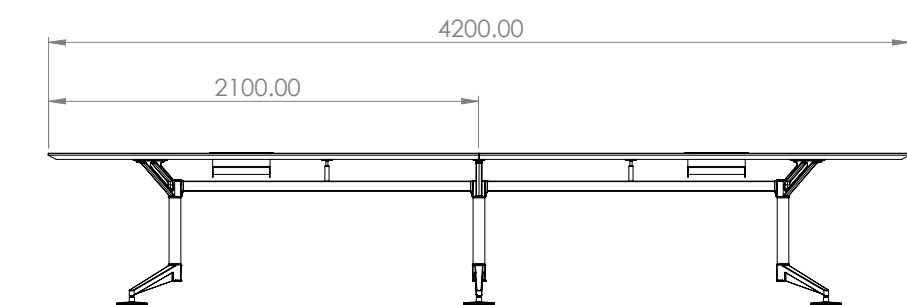

RIGHT-SIDE VIEW

TOK-TOK

TECHNICAL SPECIFICATIONS

TOK-TOK

TABLES

TOK-TOK Round 3-star 800

Materials Information

1. Tops

25mm commercial Melamine, Laminate or Veneer worktops. Solid wood or ABS edging.

2. Supports (Cantilever brackets and Outriggers)

TOK-TOK's Legs are all manufactured using Polished Aluminium. White or Black powder-coat comes as standard. Other Colours can be made available as specified.

3. Frame

TOK-TOK's frames are all manufactured using powder-coated Steel. White or Black powder-coat comes as standard. Other Colours can be made available as specified.

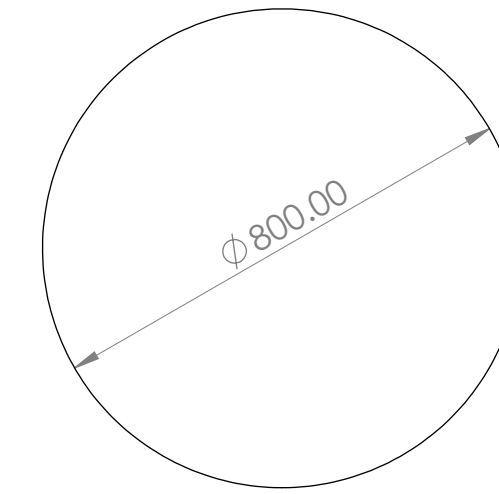

TOP VIEW

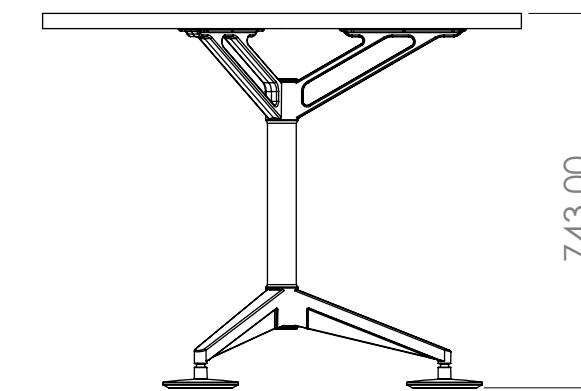

FRONT VIEW

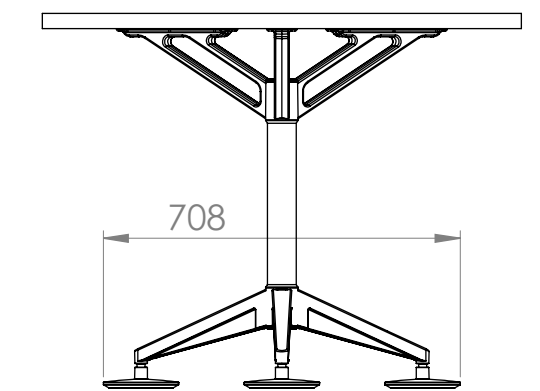

RIGHT-SIDE VIEW

TOK-TOK Round 4-star 1000

Materials Information

1. Tops

25mm commercial Melamine, Laminate or Veneer worktops. Solid wood or ABS edging.

2. Supports (Cantilever brackets and Outriggers)

TOK-TOK's Legs are all manufactured using Polished Aluminium. White or Black powder-coat comes as standard. Other Colours can be made available as specified.

3. Frame

TOK-TOK's frames are all manufactured using powder-coated Steel. White or Black powder-coat comes as standard. Other Colours can be made available as specified.

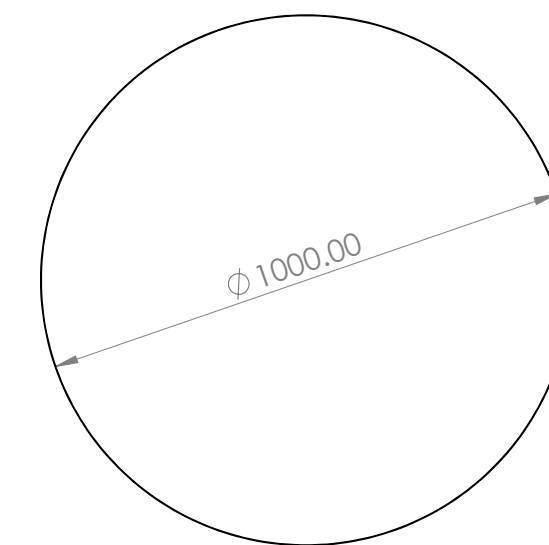

TOP VIEW

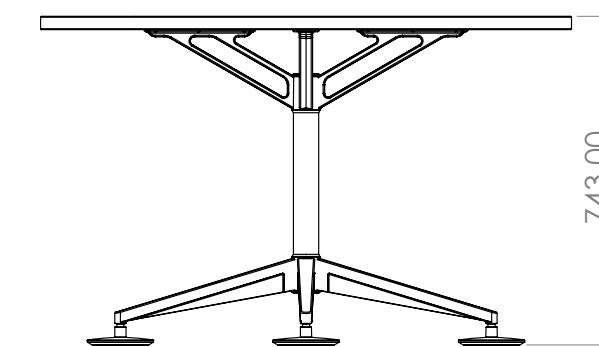

FRONT VIEW

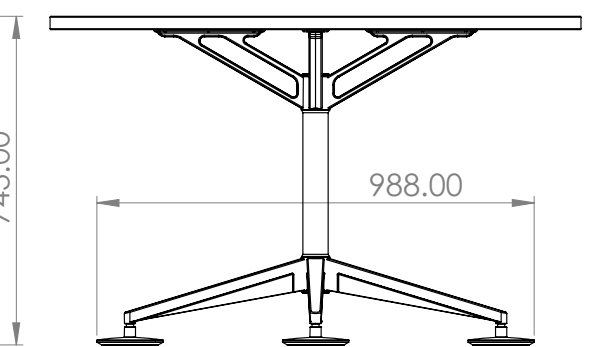

RIGHT-SIDE VIEW

TOK-TOK

TECHNICAL SPECIFICATIONS

TOK-TOK

FINISHES

Adroit and versatile, TOK-TOK yields the importance of adaptability for your own needs, offering a range of finishes and configurations to suit any office space.

1. Tops

25mm commercial Melamine, Laminate or Veneer worktops. Solid wood or ABS edging.



2. Frame

TOK-TOK's frames are all manufactured using Powder-coated Steel. White or Black powder-coat comes as standard. Other Colours can be made available as specified.

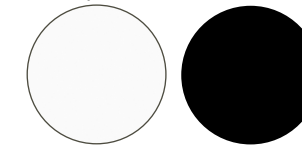

3. Supports (Cantilever brackets and Outriggers)

TOK-TOK's frames are all manufactured using Polished Aluminium or Powder-coated Steel. White or Black powder-coat comes as standard. Other Colours can be made available as specified.

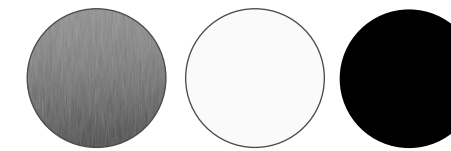



TOK-TOK

EMPOWERING COLLABORATION AND FLEXIBILITY, THE TOK-TOK RANGE HAS BEEN THOUGHTFULLY EXPRESSED TO CREATE ENVIRONMENTS WHERE INNOVATION TAKES THE FOREFRONT. WITH A SOPHISTICATED CABLE MANAGEMENT RETICULATING POWER BENEATH THE WORK SURFACE, TOK-TOK DECLUTTERS THE WORKTOP TO ENSURE YOUR WORKSPACE EMPOWERS YOU TO THE FULLEST.

SUSTAINABILITY POLICY

WE BELIEVE A TRULY SUSTAINABLE BUSINESS SHOULD EMBRACE ENVIRONMENTAL, SOCIAL AND CULTURAL VALUES. OUR PHILOSOPHY MEANS THAT WE EXAMINE EVERYTHING WE DO TO MINIMISE OUR IMPACT ON THE ENVIRONMENT STARTING WITH THE DESIGN OF OUR PRODUCTS, THE SELECTION OF MATERIALS, MANUFACTURING, ASSEMBLY AND INSTALLATION, PRACTICES IN OUR OFFICES AND ACCEPTING THE RESPONSIBILITY FOR OUR PRODUCTS' LIFE CYCLES.

ENVIRONMENTAL POLICY

RJ OFFICE HAS BEEN ON A SUSTAINABILITY JOURNEY SINCE 2008, ACHIEVING ENVIRONMENTAL PRODUCT CERTIFICATION AND IN 2009 ATTAINING ISO14001 EMS CERTIFICATION. AS PART OF OUR ENVIRONMENTAL MANAGEMENT SYSTEM, WE ARE COMMITTED TO CONTINUALLY IMPROVING OUR ENVIRONMENTAL PRACTICES TO ENSURE THAT WE MAINTAIN A BALANCE BETWEEN THE ENVIRONMENT AND OUR BUSINESS.

PRODUCT STEWARDSHIP POLICY

OUR PRODUCT STEWARDSHIP POLICY FOR RJ PRODUCTS PROVIDES USERS WITH A NUMBER OF OPTIONS.

WE ENCOURAGE OUR CUSTOMERS TO CONTACT US ABOUT RETURN OF OUR PRODUCTS. IF THE PRODUCTS CANNOT BE REUSED OR REFURBISHED, RJ OFFICE COMMITS TO TAKE THE PRODUCTS BACK, AT AN AGREED COST, AND ENSURE THAT THEY ARE DISASSEMBLED AND THE COMPONENTS ARE RECYCLED OR WHERE APPROPRIATE DISPOSED OF RESPONSIBLY.

PHONE: (02) 9299 9090

RJ OFFICE P/L
COPYRIGHT 2020
ALL RIGHTS RESERVED

SHOWROOM

25 SHELLEY ST
KING STREET WHARF
SYDNEY NSW 2000
T: +61 2 9299 9090

LOGISTICS

BUILDING 2
112 LILYFIELD ROAD
LILYFIELD NSW 2040
T: +61 2 9818 8788

info@rj.com.au
rj.com.au

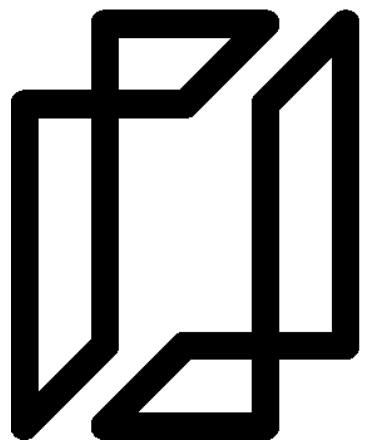

IMAGINE, INNOVATE, CREATE.

WWW.RJ.COM.AU