

SPY





SPY

The workplace is an ever changing space. Introducing the SPY by RJ Office, our response to the modern workplace. From robust workstations in both singular and back to back variations to meeting tables, SPY is beautifully designed to provide you with versatility to suit every requirement.

Influenced by the intrinsic nature of the modern office space, Spy is built on techniques and integrated features to support a modern work environment.



SPY's privacy screens provide visual and audio privacy. Screens are either clamped to static frames or available as free standing components within alternative systems.

01 The Spy Singular Workstation.

The Spy workstation comes in both Singular and back to back variations, bringing you the versatility your office space needs.

02 Leg glides.

Spy integrates soft leg gliders, making Spy suitable for any surface.

03 Fixed Joint of Spy's legs.

Spy's carefully considered fixings give it increased structural rigidity, ensuring our products stand the test of time.

04 Central compartment reticulates Power cables.

Our Cable Management tower carefully reticulates power and conceals all your cables, decluttering the workspace and giving you more freedom to move.

05 Frameless divider mounted on brackets.

Spy's mounted partitions come in both frameless and framed variations, providing you with the adaptability you need.

06 SPY's Versatility

The Versatility of the SPY ranges provides you with the a working solution for all of today demands.

07 SPY's Privacy Screens

Spy's privacy screens are available in Acoustic panel, Commercial fabrics, Acrylic or Wood finishes. Screens can be frameless, or bound by Powder-coated Aluminium frames.

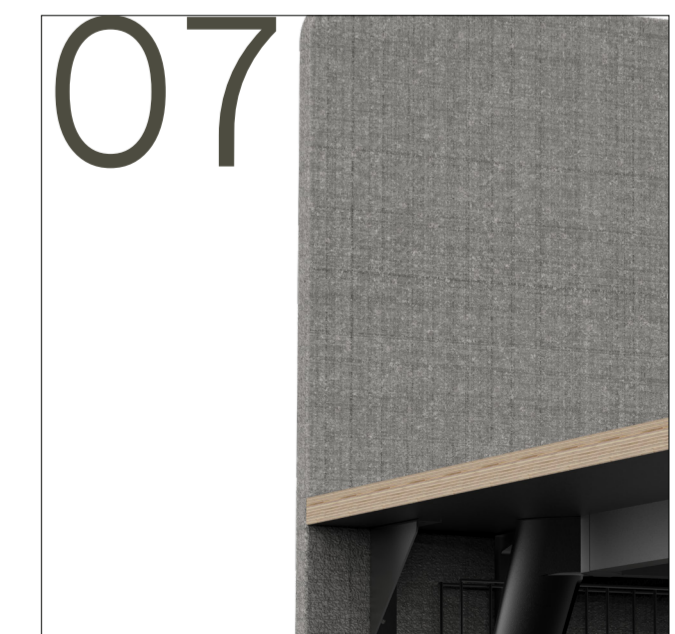
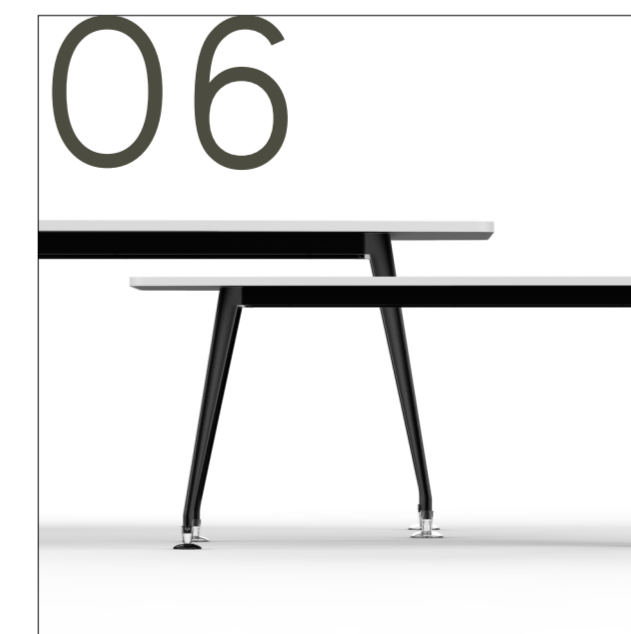
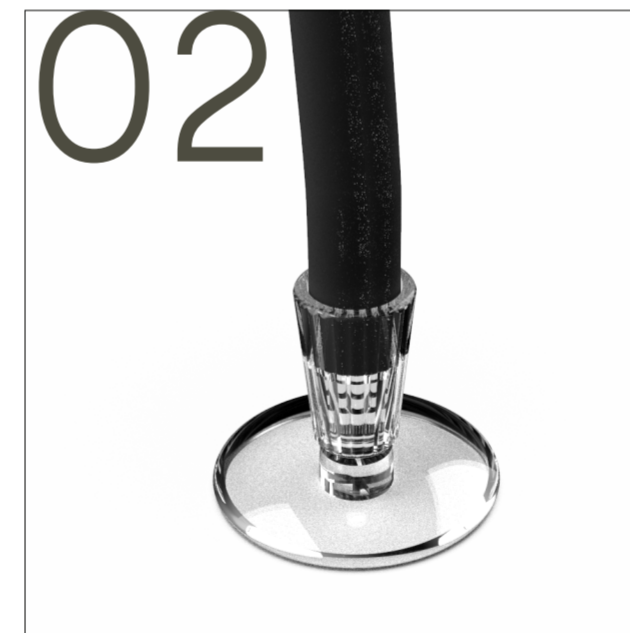

01

The versatile nature of Spy makes the product adaptable in workstation environments as well as in collaborative applications, such as meeting rooms and breakout areas.



SPY

TECHNICAL SPECIFICATIONS

SPY

WORKSTATIONS

SPY Single workstation.

Materials Information

1. Tops

25mm commercial Melamine, Laminate or Veneer worktops. Solid wood or ABS edging.

2. Legs and Frame

SPY's Legs are all manufactured using powder-coated Steel. Powder-coated Steel legs, come in both white and black variations. Other Colours can be made available as specified..

3. Frame Finishes

SPY's frames are all manufactured using powder-coated Steel. White or Black powder-coat comes as standard. Other Colours can be made available as specified.

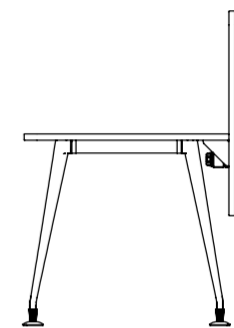
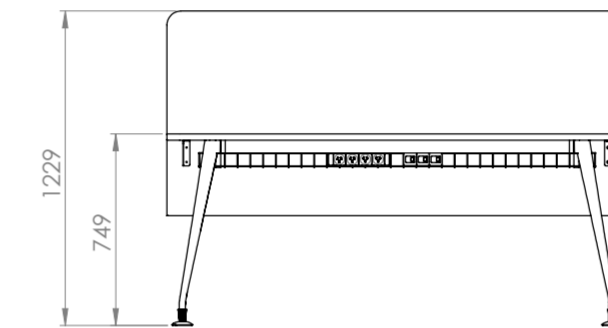
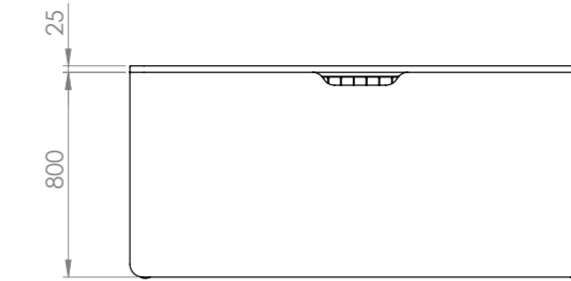

SPY Back-to-back Cluster of four Workstation

Materials Information

1. Tops

25mm commercial Melamine, Laminate or Veneer worktops. Solid wood or ABS edging.

2. Legs

SPY's Legs are all manufactured using powder-coated Steel. Powder-coated Steel legs, come in both white and black variations. Other Colours can be made available as specified.

3. Frame Finishes

SPY's frames are all manufactured using powder-coated Steel. White or Black powder-coat comes as standard. Other Colours can be made available as specified.

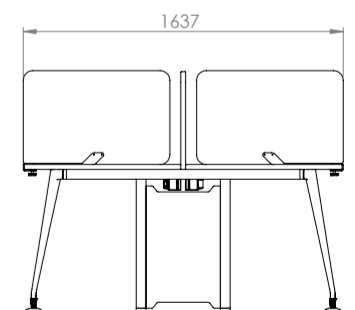
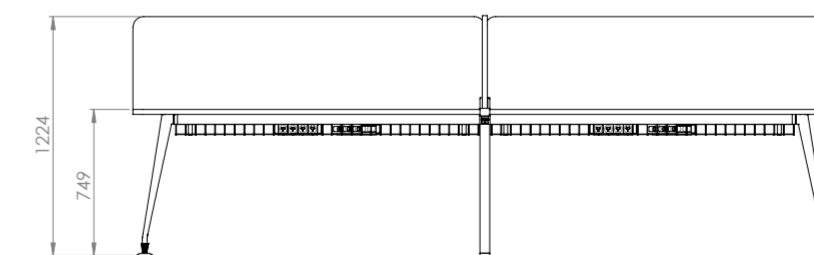
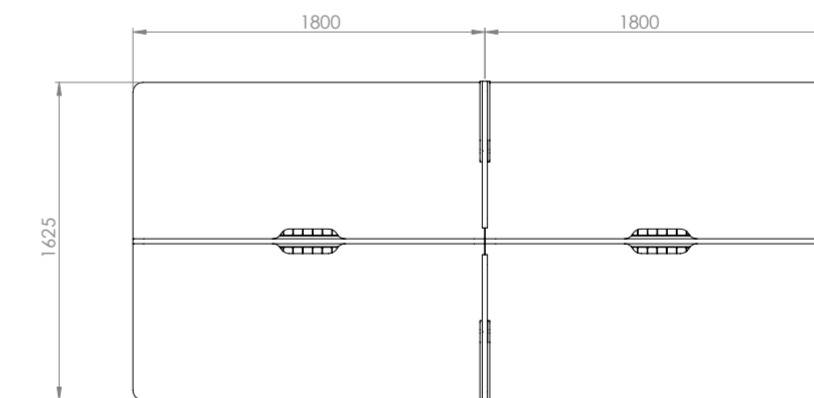



SPY

THE WORKPLACE IS AN EVER CHANGING SPACE. INTRODUCING THE SPY BY RJ OFFICE. OUR RESPONSE TO THE MODERN WORKPLACE. FROM ROBUST WORKSTATIONS IN BOTH SINGULAR AND BACK TO BACK VARIATIONS TO MEETING TABLES. SPY IS BEAUTIFULLY DESIGNED TO PROVIDE YOU WITH VERSATILITY TO SUIT EVERY REQUIREMENT.

SUSTAINABILITY POLICY

WE BELIEVE A TRULY SUSTAINABLE BUSINESS SHOULD EMBRACE ENVIRONMENTAL, SOCIAL AND CULTURAL VALUES. OUR PHILOSOPHY MEANS THAT WE EXAMINE EVERYTHING WE DO TO MINIMISE OUR IMPACT ON THE ENVIRONMENT STARTING WITH THE DESIGN OF OUR PRODUCTS, THE SELECTION OF MATERIALS, MANUFACTURING, ASSEMBLY AND INSTALLATION, PRACTICES IN OUR OFFICES AND ACCEPTING THE RESPONSIBILITY FOR OUR PRODUCTS' LIFE CYCLES.

ENVIRONMENTAL POLICY

RJ OFFICE HAS BEEN ON A SUSTAINABILITY JOURNEY SINCE 2008, ACHIEVING ENVIRONMENTAL PRODUCT CERTIFICATION AND IN 2009 ATTAINING ISO14001 EMS CERTIFICATION. AS PART OF OUR ENVIRONMENTAL MANAGEMENT SYSTEM, WE ARE COMMITTED TO CONTINUALLY IMPROVING OUR ENVIRONMENTAL PRACTICES TO ENSURE THAT WE MAINTAIN A BALANCE BETWEEN THE ENVIRONMENT AND OUR BUSINESS.

PRODUCT STEWARDSHIP POLICY

OUR PRODUCT STEWARDSHIP POLICY FOR RJ PRODUCTS PROVIDES USERS WITH A NUMBER OF OPTIONS.

WE ENCOURAGE OUR CUSTOMERS TO CONTACT US ABOUT RETURN OF OUR PRODUCTS. IF THE PRODUCTS CANNOT BE REUSED OR REFURBISHED, RJ OFFICE COMMITS TO TAKE THE PRODUCTS BACK, AT AN AGREED COST, AND ENSURE THAT THEY ARE DISASSEMBLED AND THE COMPONENTS ARE RECYCLED OR WHERE APPROPRIATE DISPOSED OF RESPONSIBLY.

PHONE: (02) 9299 9090

RJ OFFICE P/L
COPYRIGHT 2020
ALL RIGHTS RESERVED

SHOWROOM

25 SHELLEY ST
KING STREET WHARF
SYDNEY NSW 2000
T: +61 2 9299 9090

LOGISTICS

BUILDING 2
112 LILYFIELD ROAD
LILYFIELD NSW 2040
T: +61 2 9818 8788

info@rj.com.au
rj.com.au

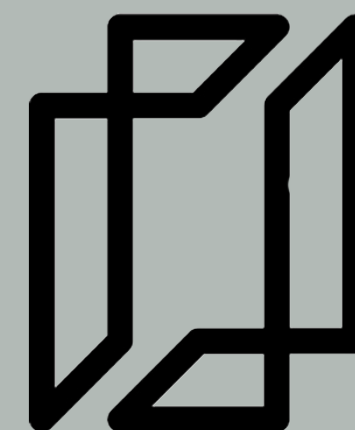

IMAGINE, INNOVATE, CREATE.

WWW.RJ.COM.AU