



CHANE



CHANE

With a contemporary feel and modern aesthetic, CHANE is our collection of thoughtfully designed desk systems that aim to create inspiring settings, allowing you to work individually or collaboratively at home or in the office.

CHANE is a desk system that has been intelligently designed to reflect the dynamic nature of modern office workspaces. Available in a range of configurations, CHANE can easily be disassembled and reassembled to create the desired work environment

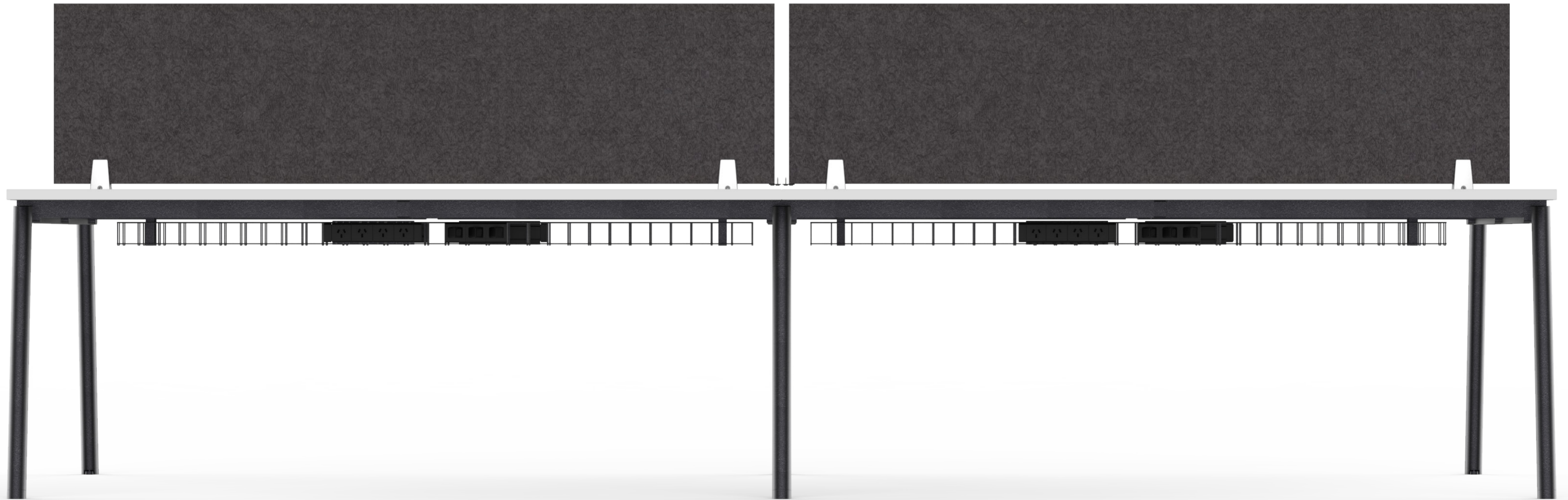

CHANE comes standard with a range of suitable privacy screen solutions, providing visual and audio privacy when needed. CHANE's screens can either be located above the desktop, or as modesty panels extending below the desk.

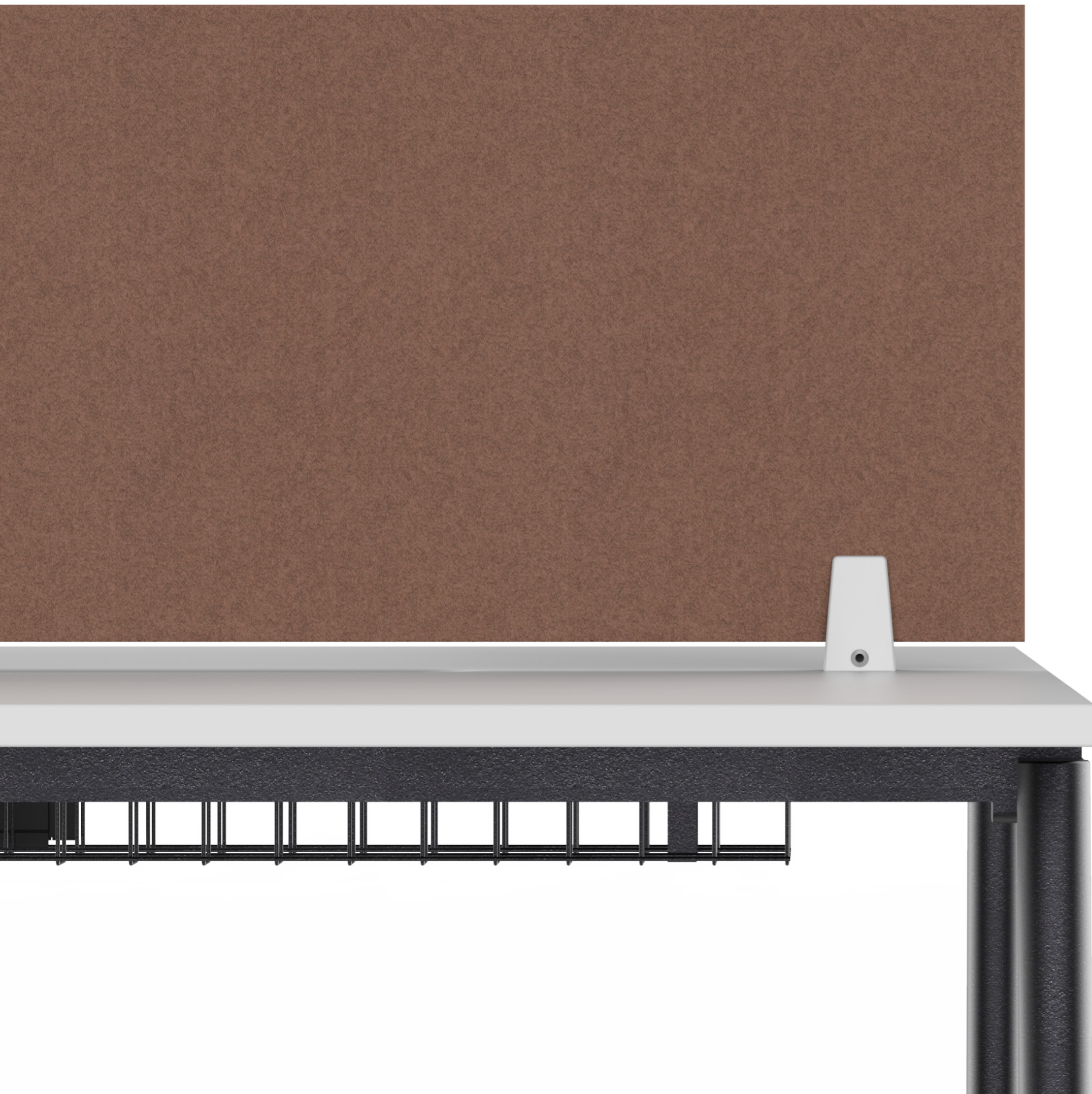

Privacy screen finishes

Screens are also available in the following finishes:

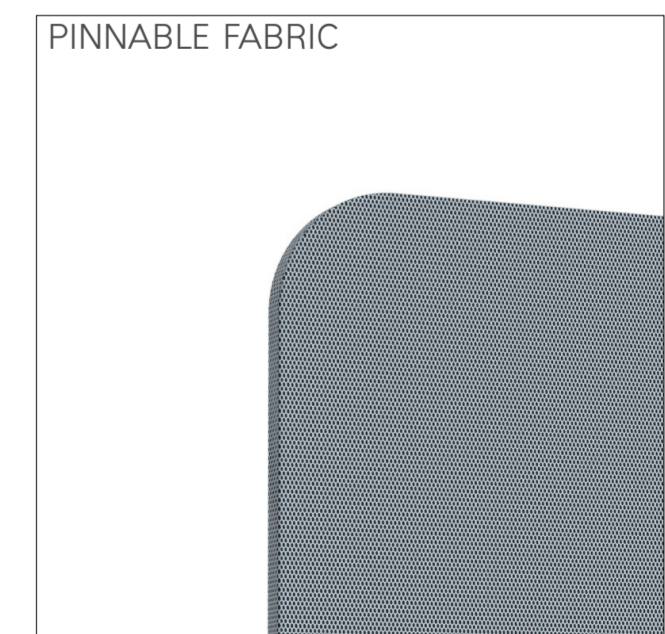
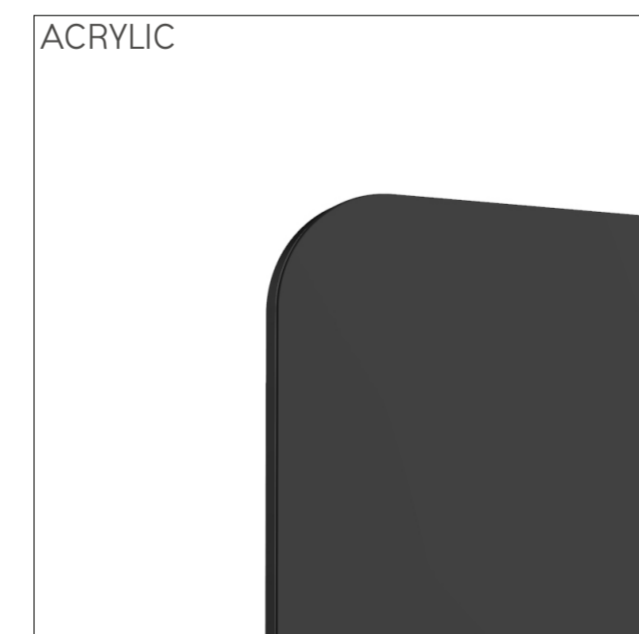
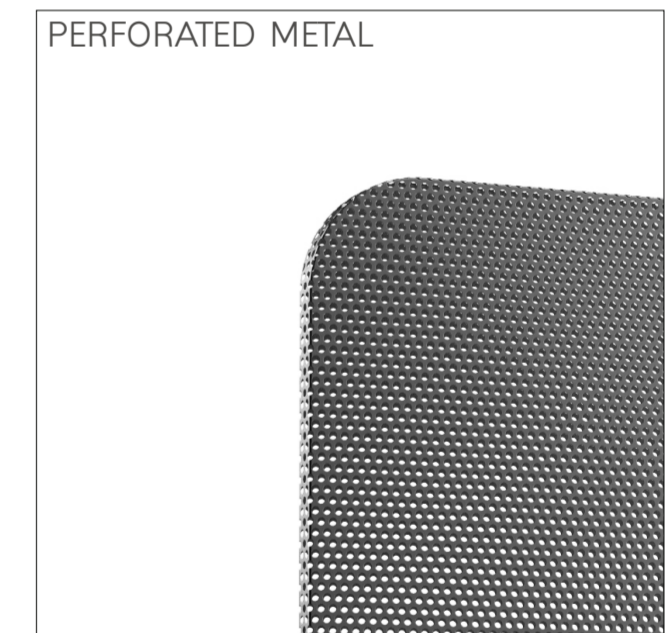

CHANE also features a fully developed cable management system. Services are reticulated and concealed by CHANE's Cable basket, freeing the workspace and providing greater working freedom.

01 The CHANE Cluster of Four Workstation.
The CHANE workstation offers a variety of configurations, available in Linear Single Desk, 90-degree desk and Side-by-side desk variations.

02 Single or Two Tier cable trays
CHANE offers both single and two tier cable tray solutions, reticulating power and data cables efficiently to free the workspace for you.

03 Power, voice and data outlets
CHANE power, voice and data outlets are carefully concealed below the desk, decluttering the your workspace.

04 In-desk power boxes or above desk power rails
CHANE adaptable power options allow you to conceal power and data cables using its in-desk power box, or externalise them using CHANE above desk power rails.

05 Vertical power management from the ceiling via Power poles, power blades or umbilicals.
CHANE brackets are fine tuned to level the table, allowing the legs of the table to sit flush to the surface.

06 CHANE's Telescopic Frame
CHANE's Telescopic Frame allows it to be flexible in nature, providing you with the versatility and freedom to alter CHANE to your specific needs.

07 CHANE accessories
The CHANE series comes with a family of accessories and adjustable add-ons, allowing you to tailor CHANE for your own individual workspace needs.



Minimal in nature, The CHANE's strut legs and sleek worktop creates a tasteful aesthetic that compliments the look of any space, whether at home or in the office.



CHANE

TECHNICAL SPECIFICATIONS

CHANE

WORKSTATIONS

CHANE Linear single desk

Materials Information

1. Tops

25mm commercial Melamine, Laminate or Veneer worktops. Solid wood or ABS edging.

2. Legs and Frame

CHANE's Legs are all manufactured using Powder-coated Steel. Powder-coated Steel legs, come in both white and black variations. Other Colours can be made available as specified.

3. Frame Finishes

CHANE's frames are all manufactured using Powder-coated Steel. White or Black Powder-coat comes as standard. Other Colours can be made available as specified.

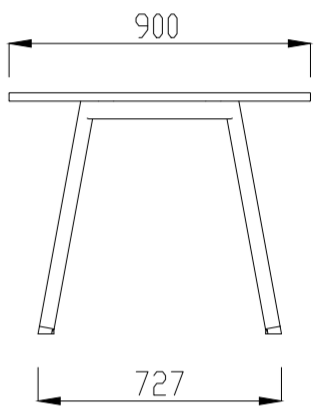
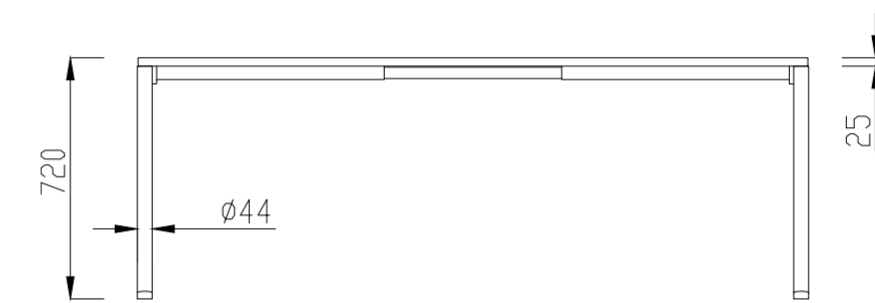
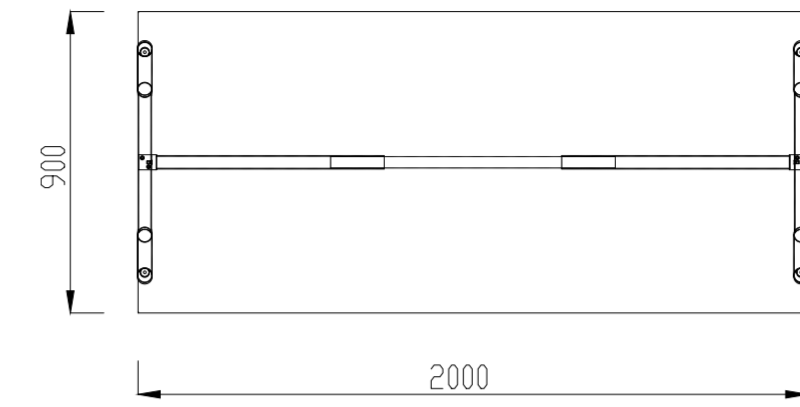

CHANE Linear 90-Degree Single desk

Materials Information

1. Tops

25mm commercial Melamine, Laminate or Veneer worktops. Solid wood or ABS edging.

2. Legs

CHANE's Legs are all manufactured using Powder-coated Steel. Powder-coated Steel legs, come in both white and black variations. Other Colours can be made available as specified.

3. Frame Finishes

CHANE's frames are all manufactured using Powder-coated Steel. White or Black Powder-coat comes as standard. Other Colours can be made available as specified.

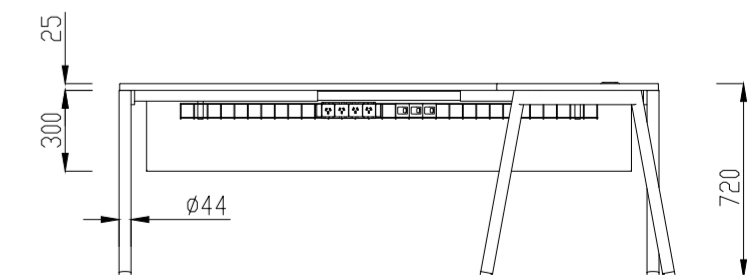
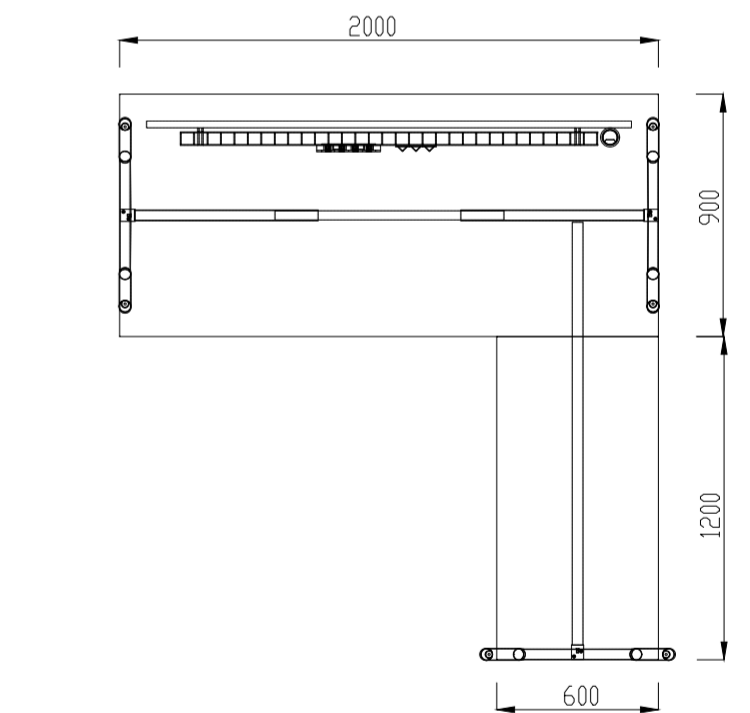
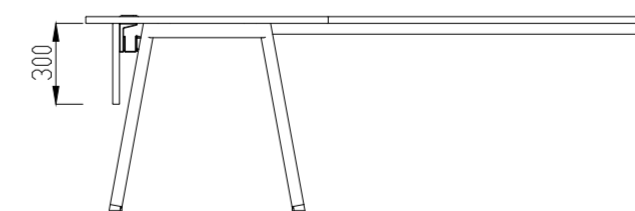

CHANE

TECHNICAL SPECIFICATIONS

CHANE

WORKSTATIONS

CHANE Cluster of four Workstation

Materials Information

1. Tops

25mm commercial Melamine, Laminate or Veneer worktops. Solid wood or ABS edging.

2. Legs and Frame

CHANE's Legs are all manufactured using Powder-coated Steel. Powder-coated Steel legs, come in both white and black variations. Other Colours can be made available as specified.

3. Frame Finishes

CHANE's frames are all manufactured using Powder-coated Steel. White or Black Powder-coat comes as standard. Other Colours can be made available as specified.

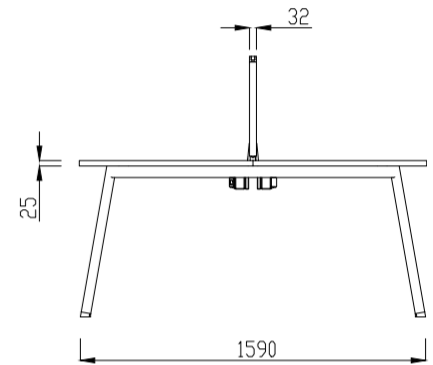
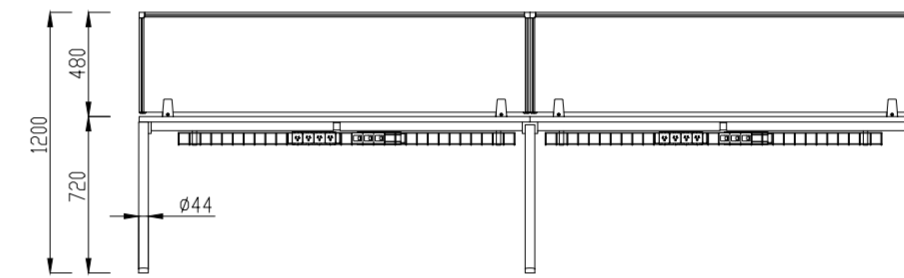
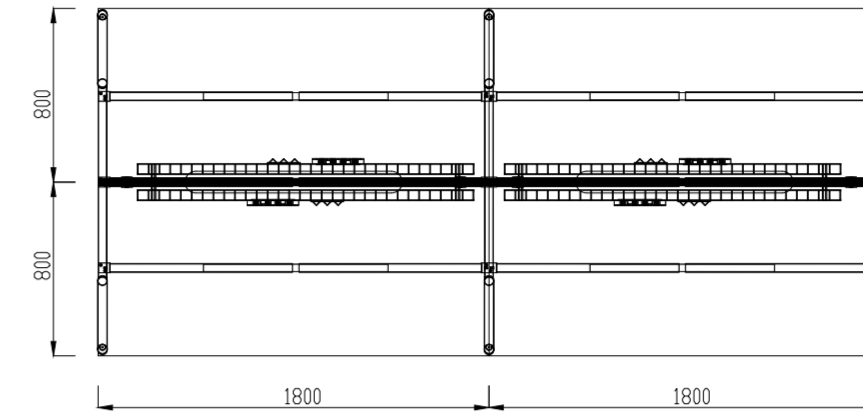

CHANE

FINISHES SPECIFICATIONS

CHANE

FINISHES

Adroit and versatile, CHANE yields the importance of adaptability for your own needs, offering a range of finishes and configurations to suit any office space.

1. Tops

25mm commercial Melamine, Laminate or Veneer worktops. Solid wood or ABS edging.



2. Legs

CHANE's Legs are all manufactured using Powder-coated Steel. Powder-coated Steel legs, come in both white and black variations. Other Colours can be made available as specified.



3. Frame Finishes

CHANE's frames are all manufactured using Powder-coated Steel. White or Black Powder-coat comes as standard. Other Colours can be made available as specified.

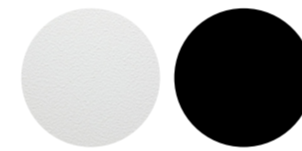



CHANE

WITH A CONTEMPORARY FEEL AND MODERN AESTHETIC, CHANE IS OUR COLLECTION OF THOUGHTFULLY DESIGNED DESK SYSTEMS THAT AIM TO CREATE INSPIRING SETTINGS, ALLOWING YOU TO WORK BETTER TOGETHER.

SUSTAINABILITY POLICY

WE BELIEVE A TRULY SUSTAINABLE BUSINESS SHOULD EMBRACE ENVIRONMENTAL, SOCIAL AND CULTURAL VALUES. OUR PHILOSOPHY MEANS THAT WE EXAMINE EVERYTHING WE DO TO MINIMISE OUR IMPACT ON THE ENVIRONMENT STARTING WITH THE DESIGN OF OUR PRODUCTS, THE SELECTION OF MATERIALS, MANUFACTURING, ASSEMBLY AND INSTALLATION, PRACTICES IN OUR OFFICES AND ACCEPTING THE RESPONSIBILITY FOR OUR PRODUCTS' LIFE CYCLES.

ENVIRONMENTAL POLICY

RJ OFFICE HAS BEEN ON A SUSTAINABILITY JOURNEY SINCE 2008, ACHIEVING ENVIRONMENTAL PRODUCT CERTIFICATION AND IN 2009 ATTAINING ISO14001 EMS CERTIFICATION. AS PART OF OUR ENVIRONMENTAL MANAGEMENT SYSTEM, WE ARE COMMITTED TO CONTINUALLY IMPROVING OUR ENVIRONMENTAL PRACTICES TO ENSURE THAT WE MAINTAIN A BALANCE BETWEEN THE ENVIRONMENT AND OUR BUSINESS.

PRODUCT STEWARDSHIP POLICY

OUR PRODUCT STEWARDSHIP POLICY FOR RJ PRODUCTS PROVIDES USERS WITH A NUMBER OF OPTIONS.

WE ENCOURAGE OUR CUSTOMERS TO CONTACT US ABOUT RETURN OF OUR PRODUCTS. IF THE PRODUCTS CANNOT BE REUSED OR REFURBISHED, RJ OFFICE COMMITS TO TAKE THE PRODUCTS BACK, AT AN AGREED COST AND ENSURE THAT THEY ARE DISASSEMBLED AND THE COMPONENTS ARE RECYCLED OR WHERE APPROPRIATE DISPOSED OF RESPONSIBLY.

PHONE: (02) 9299 9090

**RJ OFFICE P/L
COPYRIGHT 2020
ALL RIGHTS RESERVED**

SHOWROOM
25 SHELLEY ST
KING STREET WHARF
SYDNEY NSW 2000
T: +61 2 9299 9090

LOGISTICS
BUILDING 2
112 LILYFIELD ROAD
LILYFIELD NSW 2040
T: +61 2 9818 8788

info@rj.com.au
rj.com.au

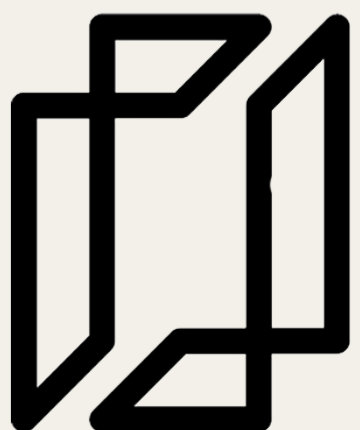

IMAGINE, INNOVATE, CREATE.

WWW.RJ.COM.AU